

PSX 16

Electric Stacker Truck
Foldable Ride-on Platform
Side Protection Bars
Optional with Lithium-ion battery
1600 kg

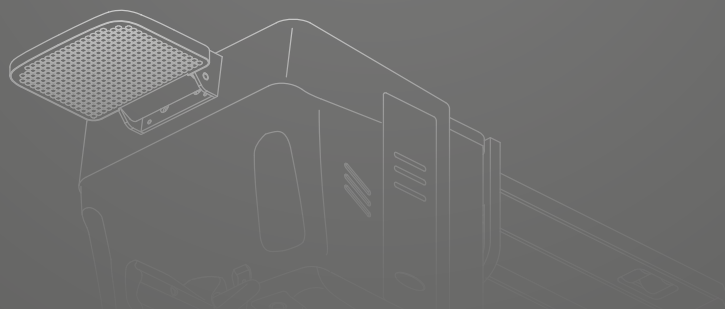
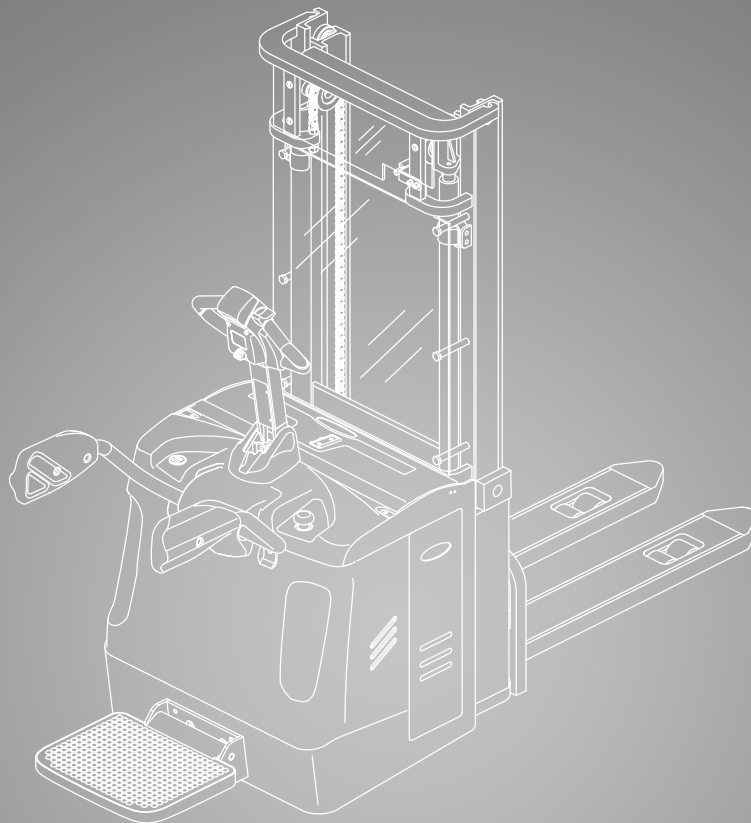

DIMENSIONS

PSX16

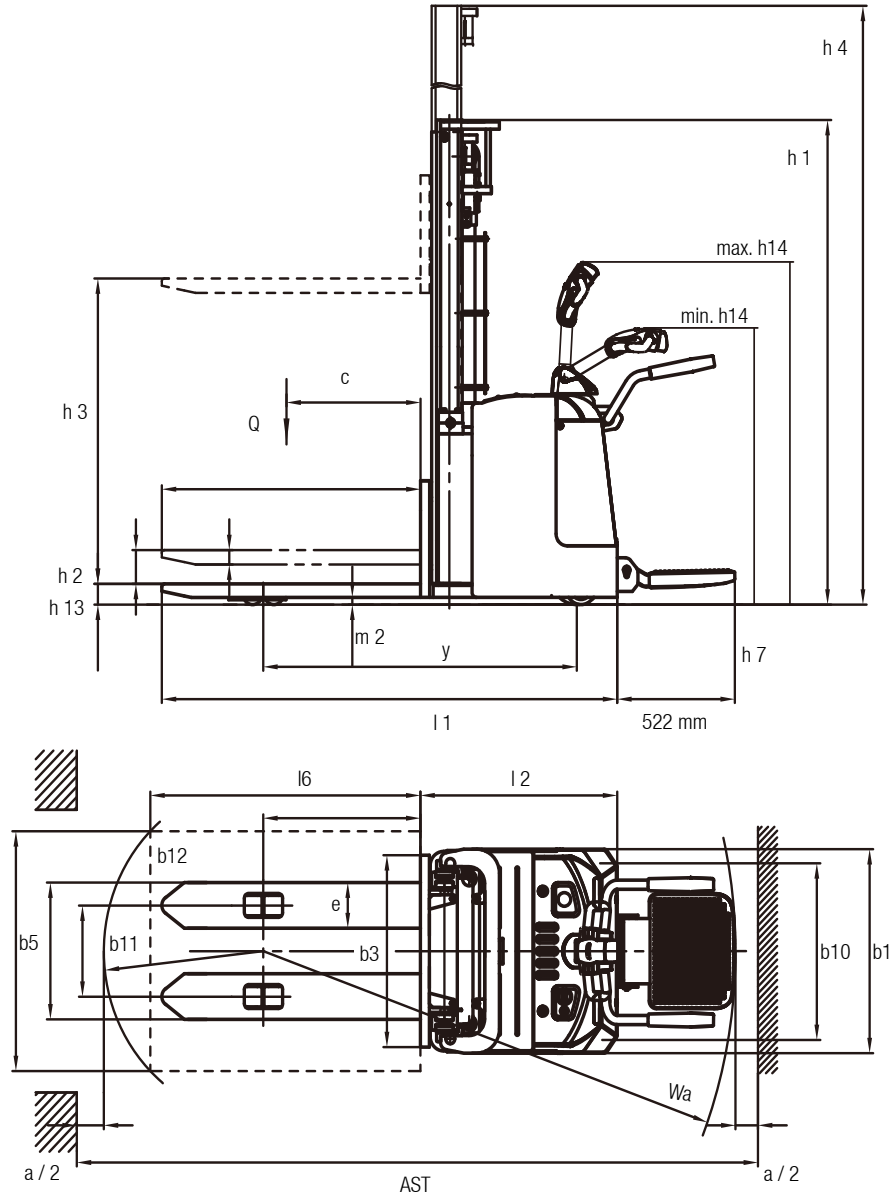

$$R_h = \sqrt{x^2 + \left(\frac{b_{12}}{2}\right)^2}$$

$$A_{st} = W_a + l_6 - x + a \quad \text{wenn } R_h < W_a$$

$$A_{st} = R_h + l_6 - x + a \quad \text{wenn } R_h > W_a$$

For corresponding data see specification chart.

SPECIFICATIONS



Product Specifications acc. to VDI 2198

1.1 Manufacturer (Abbreviation)		CLARK	CLARK	
Specifications	1.2 Manufacturer's designation	PSX16	PSX16 Li-ion	
	1.3 Drive	24V Electric		
	1.4 Operator type	Stand-on / Pedestrian		
	1.5 Rated capacity/rated load	Q (kg)	1600	
	1.6 Load centre distance	c (mm)	600	
	1.8 Load distance	x (mm)	693	
	1.9 Wheelbase	y (mm)	1375	
Weight	2.1 Service weight incl. battery (see 6.5)	kg	1240	
	2.2 Axle loading, laden front/rear	kg	960 / 1880	
	2.3 Axle loading, unladen front/rear	kg	860 / 380	
Tyres, Chassis	3.1 Tyres	Polyurethane		
	3.2 Tyre size, front	Ø 230 x 75		
	3.3 Tyre size, rear	Ø 85 x 70		
	3.4 Additional wheels (dimensions)	Ø 130 x 55		
	3.5 Wheels, number front/rear (x = driven wheels)	1 x + 1 / 4		
	3.6 Tread, front	b10 (mm)	574	
	3.7 Tread, rear	b11 (mm)	380	
Dimensions	4.2 Height, mast lowered	h1 (mm)	2020	
	4.3 Free lift	h2 (mm)	100	
	4.4 Lift *1	h3 (mm)	2912	
	4.4.1 Lift height	h3 + h13 (mm)	3000	
	4.5 Height, mast extended	h4 (mm)	3465	
	4.8 Stand height	h7 (mm)	160	
	4.9 Height tiller in driving position min./max.	h14 (mm)	1150 / 1480	
	4.15 Height, lowered	h13 (mm)	88	
	4.19 Overall length (Platform raised / down)	l1 (mm)	2030 / 2552	
	4.20 Length to face of forks	l2 (mm)	879	
	4.21 Overall width	b1 (mm)	850	
	4.22 Fork dimensions	s • e • l (mm)	60 x 190 x 1150	
	4.24 Fork carriage width	b3 (mm)t	800	
	4.25 Distance between fork-arms	b5 (mm)	570	
	4.32 Ground clearance, centre of wheelbase	m2 (mm)	28	
4.34 Aisle width for pallets 1000 x 1200 sideways *3	Ast (mm)	2605 / 2965		
4.34.1 Aisle width for pallets 800 x 1200 lengthways *3	Ast (mm)	2575 / 2935		
4.35 Turning radius *3	Wa (mm)	1730 / 2090		
Performance	5.1 Travel speed, laden/unladen	km/h	8 / 8	
	5.2 Lift speed, laden/unladen	m/s	0.13 / 0.16	
	5.3 Lowering speed, laden/unladen	m/s	0.22 / 0.13	
	5.8 Max. gradeability, laden/unladen *2	%	8 / 16	
	5.10 Service brake		Electric	
Electrics	6.1 Drive motor rating S2 60 min	kW	1.6	
	6.2 Lift motor rating at S3 15 %	kW	3.0	
	6.3 Battery acc. to DIN 43531/35/36 A, B, C, no		Yes	No
	6.4 Battery voltage/nominal capacity	Ah (5hr)	24 V / 375	24 V / 205
	6.5 Battery weight	kg	212 / 288	60 + Additional weight
	6.6 Energy consumption acc. to VDI cycle	kg	-	
	- Battery type		Traction battery	Lithium-ion battery
	8.1 Type of drive unit		AC	
Misc.	10.5 Steering design	Electric servo steering		
	10.7 Sound pressure level at the driver's seat acc. to EN 12053	dB(A)	74	

*1) Further lift heights see upright table *2) At friction coefficient $\mu=0.6$ with 1.6 km/h

*3) Platform raised / down, dimensions relative to battery compartment (see additional table)

All data refer to trucks in standard design.

Performance may vary + 5 % and - 10 % due to motor and system efficiency tolerance. The performance shown represents nominal values which may be obtained under typical operating conditions of a machine. CLARK products and specifications are subject to change without notice.

GENERAL DATA

Upright table PSX16 / PSX16 Li-ion

Mast type	Lift height (h3+h13)	Mast lowered (h1)	Mast extended (h4)	Free lift (h2)
	mm	mm	mm	mm
Standard	2700	1870	3165	100
	3000	2020	3465	100
	3300	2170	3765	100
	3600	2320	4065	100
	3900	2470	4365	100
Triplex	4000	1822	4460	1390
	4500	2022	4960	1590
	4800	2122	5260	1690
	5000	2187	5460	1760
	5300	2278	5760	1840
	5500	2352	5910	1910
	5800	2452	6210	2010
Hi-Lo	2700	1820	3135	1320
	3000	1970	3435	1470
	3300	2120	3735	1620

Truck dimensions relative to battery compartment

Dimension	Model		PSX16		
	Battery		Traction battery*		Lithium-ion
Battery compartment type			L	XL	Li-ion
6.4 Battery capacity	Ah		250 / 375	500	205
1.9 Wheelbase	y mm		1375	1447	1375
4.19 Overall length	with raised platform with lowered platform	L1 mm	2030 2552	2100 2622	2030 2552
4.20 Length to face of forks	with raised platform with lowered platform	L2 mm	879 1401	951 1473	879 1401
4.34 Aisle width for pallets 1000 x 1200 sideways	with raised platform with lowered platform	Asr mm	2605 2965	2675 3035	2605 2965
4.34.1 Aisle width for pallets 800 x 1200 lengthways	with raised platform with lowered platform	Ast mm	2575 2935	2648 3008	2575 2935
4.35 Turning radius	with raised platform with lowered platform	Wa mm	1730 2090	1802 2162	1738 2098
6.5 Battery weight (min/max)	kg		212 / 288	362 / 380	60 + Additional weight

* Side battery removal possible depending on version

PRODUCT DESCRIPTION

PSX16

Electrical lift and manual lowering

- Sensitive lifting and lowering
- Drive and operating controls in easy reach position
- Automatic braking when the control arm is released
- Suitable for both left- and right-handed users

Display

- Battery discharge indicator
- Operating hour counter
- Battery management system
- On-board diagnostics via error code

Application

- For use on medium to long transport routes
- Powerful 24 Volt
- Smooth and quiet operation
- Electric power steering
- Manoeuvrable in the tightest of spaces due to folding platform
- Programmability for adapted driving behavior

Batteries

- Lithium-ion battery with 205 Ah available
- Fast charging times
- In just 10 minutes, 7% battery capacity of the lithium-ion battery can be recharged
- Always usable with the lithium-ion battery from top-up charging
- The Lithium-ion battery can be recharged at any 230 V socket
- Battery capacity for lead-acid batteries up to 500 Ah
- For lead acid batteries there are two different battery compartments available: for 375 Ah or 500 Ah Batteries
- Battery change tables are available separately

Safety

- Low step height of the platform of only 160 mm makes it easier to get on and off
- Roll-back protection on gradients
- Automatic speed reduction when cornering
- When leaving the platform, the truck automatically switches to stand-by mode and can no longer be moved

Productivity and ergonomics for demanding operations with up to 5800 mm lift height.

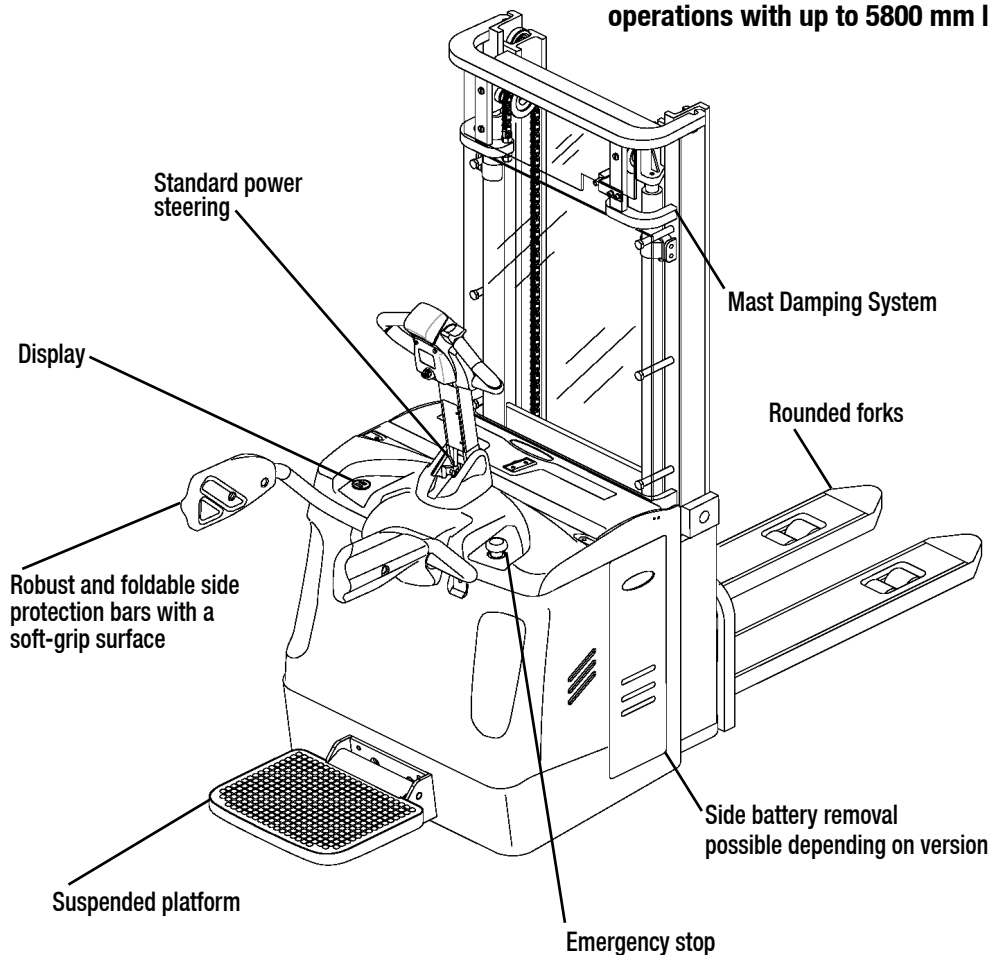

PSX16 with driver's platform and side guards

CLARK products, illustrations and specifications are subject to change without notice.

FEATURES & EQUIPMENT EXTRAS



		PSX16
General	Reliable low-maintenance AC traction motor	•
	Initial lift version	–
	Foldable driver's platform	•
	Side protection bars	•
	Proportional hydraulics system	•
	Enclosed upright damping (lifting)	–
	Enclosed upright damping (lowering)	•
	Protected lift cylinders	•
	Pallet entry wheel (for initial lift version only)	–
	Steel fabricated battery cover	•
	Large residual capacities due to 4-wheel layout	•
Drive and Battery Options	Single load wheel (Polyurethane)	X
	Tandem load wheel (Polyurethane)	•
	Electric servo steering	•
	Profiled traction wheel	X
	Battery discharge indicator	•
	Side battery removal	X
	Lithium-ion battery with 205 Ah	X
Battery compartment sizes for lead-acid batteries: 250 Ah, 375 Ah or 500 Ah batteries	X	
Miscellaneous	Key switch activation	•
	Pin-code activation	–
	Mast safety guard: PVC mast screen	•
	Mast safety guard: wire mesh	–
	Push button for operation with vertical tiller	–
	Load backrest (Height 1220 mm / 820 mm width)	–
	Large residual capacities	•
	Tiller arm in a central position for symmetrical operation	•
	Automatic lift stop (at max. lift)	•
	Automatic parking brake	•
Safety	Comfort and safety tiller	•
	Crawl speed switch	–
	Anti-slip platform surface	•
	Low platform height of only 160 mm	•
	Automatic standby mode when the driver steps off the platform	•

• = Standard Equipment; x = Option; – = Not Available

CLARK Europe GmbH

Dr.-Alfred-Herrhausen-Allee 33

47228 Duisburg / Germany

Tel.: +49 (0)2065 499 13-0

Fax: +49 (0)2065 499 13-290

E-Mail: Info-europe@clarkmheu.com

www.clarkmheu.com

Dealer: