



## SV 12 Technical Data

Stand-on high lift truck



In accordance with VDI guidelines 2198, this specification applies to the standard model only.  
Alternative tyres, mast types, ancillary equipment, etc. could result in different values.

Characteristics	1.1	Manufacturer			STILL
	1.2	Manufacturer's model designation			SV 12
	1.3	Power supply (electric, diesel, petrol, gas, mains electric)			electric
	1.4	Type of control (hand, pedestrian, stand-on, rider seated, order picker)			electric
	1.5	Capacity/load	Q	kg	1200
	1.6	Load centre	c	mm	600
	1.8	Load distance	lowered x	mm	690
	1.9	Wheelbase	lowered y	mm	1450
	Weight	2.1	Weight (incl. battery)		kg
2.2		Axle loadings laden	drive end/load end	kg	980/1650
2.3		Axle loadings unladen	drive end/load end	kg	940/460
Wheels   Tyres	3.1	Tyres (rubber, pneumatic, polyurethane)			Polyurethane
	3.2	Tyre size	drive end	mm	ø 250 x 100
	3.3	Tyre size	load end	mm	4 x ø 85 x 60
	3.4	Support rollers	drive end	mm	2 x ø 125 x 50
	3.5	Wheels, number (x = drive wheel)	drive end/load end		1x/3/4
	3.6	Track width	drive end	b <sub>10</sub> mm	507
	3.7	Track width	load end	b <sub>11</sub> mm	380
Dimensions	4.2	Closed mast height	h <sub>1</sub>	mm	see mast table
	4.3	Free lift	h <sub>2</sub>	mm	see mast table
	4.4	Lift height	h <sub>3</sub>	mm	see mast table
	4.5	Height, mast raised	h <sub>4</sub>	mm	see mast table
	4.6	Initialhub	h <sub>5</sub>	mm	80
	4.9	Height of steering wheel	min. max. h <sub>14</sub>	mm	1345
	4.15	Height lowered	h <sub>13</sub>	mm	90
	4.19	Overall length	l <sub>1</sub>	mm	2080
	4.20	Length to front face of forks	l <sub>2</sub>	mm	930
	4.21	Overall width	b <sub>1</sub>	mm	796
	4.22	Fork dimensions	s/e/l	mm	54/184/1150
	4.24	Fork carriage width	b <sub>3</sub>	mm	680
	4.25	Overall fork width	b <sub>5</sub>	mm	564
4.31	Floor clearance, centre of wheelbase	m <sub>1</sub>	mm	30	
4.34	Working aisle width with 800 x 1200 pallet lengthwise	A <sub>st</sub>	mm	2340	
4.35	Outer turning radius	W <sub>a</sub>	mm	1630	
Performance	5.1	Speed	laden/unladen	km/h	7/9
	5.2	Lifting time	laden/unladen	m/s	0.17/0.20
	5.3	Lowering time	laden/unladen	m/s	0.37/0.31
	5.8	Gradeability	laden/unladen	%	8/12
	5.9	Acceleration time (over 10 m)	laden/unladen	s	7.3/5.6
	5.10	Brakes			electric
Electric Motors	6.1	Drive motor, rating S2 = 60 min.		kW	2.0
	6.2	Hoist motor, rating at S3 = 15 %		kW	3.0
	6.4	Battery voltage, capacity K <sub>5</sub>		V/Ah	24/420
	6.5	Battery weight ± 5 % (depending on manufacturer)		kg	370
	6.6	Energy consumption according to VDI cycle		kWh/h	1.1
	Other	8.1	Drive control		
8.4		Noise peak at operator's ears		dB (A)	< 70

### Mast table.

SV 12							
Tele mast				HiLo mast			
h <sub>1</sub>	h <sub>2</sub>	h <sub>3</sub>	h <sub>4</sub>	h <sub>1</sub>	h <sub>2</sub>	h <sub>3</sub>	h <sub>4</sub>
2225	150	3445	3980	2225	1690	3445	3980
2275	150	3545	4080	2275	1740	3545	4080
2375	150	3745	4280	2375	1840	3745	4280
2575	150	4145	4680	2575	2040	4145	4680

### Capacity table.

kg	up to h <sub>3</sub> mm
1200	2700
1100	3000
1000	3300
900	3600
800	3900
600	4145

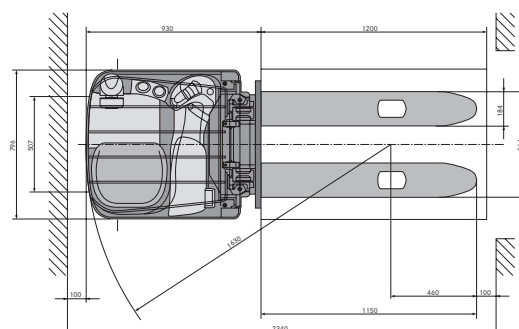
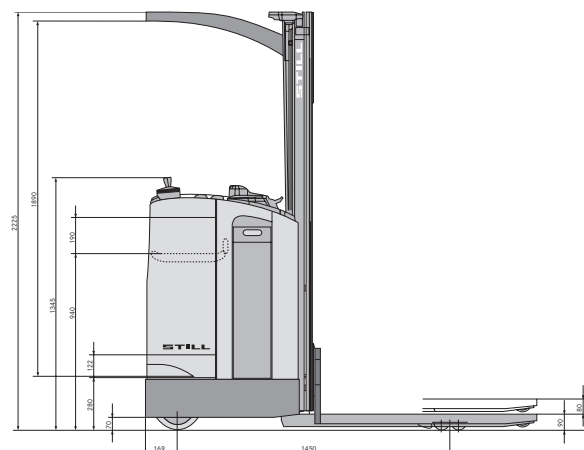

## The STILL SV 12.

- Stand-on high lift pallet truck designed for a high turnaround of goods in racking, when loading and unloading, as well as for horizontal transport of goods up to 1200 kg.
- With compact length and overall width of less than 800 mm, normal commercial pallets can be handled. The SV is also very flexible when used for order picking and as a working/lifting table.

### Driver's compartment.

- The driver's standing compartment is also fitted with a bucket seat to allow the driver to be seated if required.
- A high level of driving comfort is achieved with the padded interior plus integral storage facilities for working papers and utensils.
- Gas-damped non-slip footplate and seat can be adjusted for height by up to 180 mm. Adjustment is smooth and easily achieved by a simple push of a button.
- The controls fall easily to hand without changing grip and a clear layout avoids confusion. Drive direction and travel speed are controlled by a butterfly switch with integral buttons for hoist and lower functions.
- Footrests on the right of the footwell prevent fatigue during long horizontal transport runs.
- Standard display gives battery discharge, operating hours and fault code read-outs.

### Chassis.

- Very good all round vision and a clear view onto the fork tips thanks to the new rounded chassis contours.
- Robust, torsionally rigid steel frame consists of drive section and load lifting section.
- A patented hinged section gives ideal access to the electrical components. Ease of servicing reduces maintenance costs.
- Good weight distribution and reduced point loading due to the 4-wheel principle - ideal for upper storey use.
- Patented friction aids on the fork tips allow non-slip pallet handling.

### Steering.

- Full electric steering for 180° lock-to-lock movement without kickback. Steering wheel diameter of only 120 mm and 4½ turns guarantees fast, effortless steering.
- The steer motor is protected against shocks from uneven floors by a safety coupling.
- Automatic reduction of speed when driving round corners, thereby ensuring a high level of safety.

### Drive.

- A robust 2.0 kW shunt wound drive motor provides quick acceleration and powerful ramp travel. Efficient energy utilisation due to the spur and bevel gear transmission.

### Hydraulics.

- The hydraulic unit consists of a powerful, high efficiency 3.0 kW pump motor actuated via push buttons in the operating panel.
- Particularly sensitive control is achieved with the proportional valve technology fitted as standard for the main hoist.
- Automatic shut-off of the initial lift is achieved by an overload protection for the hydraulic pump - saving energy and reducing noise.

### Brakes.

- Two independent braking systems are fitted.
- Generator braking activated by releasing the butterfly switch or changing drive direction guarantees soft braking and protects the brake linings. During braking the drive unit acts as a generator and puts the recovered energy back into the battery.
- An electromagnetic brake acts as a parking brake and emergency brake.
- Starting on gradients is possible without roll-back.
- Automatic brake monitoring is achieved by means of a load sensor, which regulates the braking current to suit the load.

### Battery.

- For multi-shift use the battery is changed using the patented battery free lift and a roller track at the side.

### Auxiliary equipment.

- Wheel position indicator.
- Return control.
- FleetManager light.



КОМПЛЕКСНАЯ АВТОМАТИЗАЦИЯ  
ИНДУСТРИАЛЬНЫХ ТЕРМИНАЛОВ

Официальный диллер STILL GmbH в России

Тел.: 8-800-50-55-020

Москва, Авангардная 3,  
офис № 1507

[www.comitas.ru](http://www.comitas.ru)  
[info@comitas.ru](mailto:info@comitas.ru)