

Pedestrian lowlifter truck 2.4 ton

BT levio

P-series

LPE240



Pedestrian lowlifter

Specification for lowlifter trucks					LPE240
Identification	1.1	Manufacturer			Toyota
	1.2	Model			LPE240
	1.3	Drive			Electric
	1.4	Operator type			Pedestrian
	1.5	Load capacity/rated load	Q	kg	2400
	1.6	Load centre	c	mm	600
	1.8	Load distance, centre of support arm wheel to face of forks	x	mm	909
	1.9	Wheelbase, fork raised/lowered	y	mm	1605/1725
	Weight	2.1	Service weight with battery		kg
2.2		Axle load, with load, drive/castor/fork wheel		kg	835/590/2150
2.3		Axle load, without load, drive/castor/fork wheel		kg	510/300/210
Wheels	3.1	Drive/castor/fork wheel			Vulkollan
	3.2	Wheel size, front		mm	Ø 250
	3.3	Wheel size, rear		mm	Ø 85x75 ¹⁾
	3.4	Additional wheels (dimensions)		mm	Ø 150 x 50
	3.5	Wheels, number front/rear (x=driven wheels)			2-1x/4
	3.6	Track width, front	b ₁₀	mm	547
	3.7	Track width, rear	b ₁₁	mm	370
Dimensions	4.4	Lift	h ₃	mm	125
		Lift height	h ₂₃	mm	210*
	4.8	Stand height	h ₇	mm	184
	4.9	Height of tiller in drive position, min./max.	h ₁₄	mm	1085/1450
	4.15	Height, fork lowered	h ₁₃	mm	85
	4.19	Overall length	l ₁	mm	1895
	4.20	Length to face of forks	l ₂	mm	745
	4.21	Overall width	b ₁	mm	790
	4.22	Fork dimensions	s/e/l	mm	78/180/1150
	4.25	Width over forks	b ₅	mm	550
	4.32	Ground clearance, centre of wheelbase	m ₁	mm	34
	4.33	Aisle width for pallets 1000x1200 crossways	A _{st}	mm	2016
	4.34	Aisle width for pallets 800x1200 lengthways	A _{st}	mm	2216
4.35	Turning radius	W _a	mm	1725	
Performance data	5.1	Travel speed, with/without load		km/h	8,5/12,0 ²⁾
	5.2	Lift speed, with/without load		m/s	0,04/0,06
	5.3	Lowering speed, with/without load		m/s	0,04/0,04
	5.8	Max. gradeability, with/without load		%	8/15 ³⁾
	5.10	Service brake			Electric
Electric motor	6.1	Drive motor rating S2 60 min		kW	2,5
	6.2	Lift motor rating at S3 10%		kW	2,2
	6.4	Battery voltage/nominal capacity K ₅		V/Ah	24/450
	6.5	Battery weight		kg	380
Others	8.1	Type of drive control			BT Powerdrive
	8.4	Sound level at the driver's ear acc to EN12 053		dB(A)	58

1) Single wheels up to and including l = 1450 mm

2) With rated load, medium battery compartment: Travel speed = 8.0 km/h

3) Measured according to company standard

* = Other lift height available for roll container: 225mm

Data is based on standard battery compartment, medium size, l = 1150 mm

All data are based on table configuration. Other configurations may give other values.

Truck performance and dimensions are nominal and subject to tolerances.

Toyota Material Handling Manufacturing Sweden AB products and specifications are subject to change without notice.

Battery dependent dimensions

BT levio

Dimensions		LPE240			
		Battery compartment		Small	Medium
1.9	Wheelbase, fork raised/lowered	y	mm	1605/1725	1691/1811
4.19	Overall length with platform up/down	l_1	mm	1895/2317	1981/2403
4.20	Length to face of forks with platform up/down	l_2	mm	745/1167	831/1253
4.33	Aisle width for pallets 1000x1200 crossways, with platform up/down	A_{st}	mm	2016/2438	2102/2524
4.34	Aisle width for pallets 800x1200 lengthways, with platform up/down	A_{st}	mm	2216/2638	2302/2724
4.35	Turning radius with platform up/down	W_a	mm	1725/2147	1811/2233
6.4	Battery voltage, nominal capacity K_s		V/Ah	24/300-465	24/300-620
6.5	Battery weight, min.—max.		kg	250—380	280—500

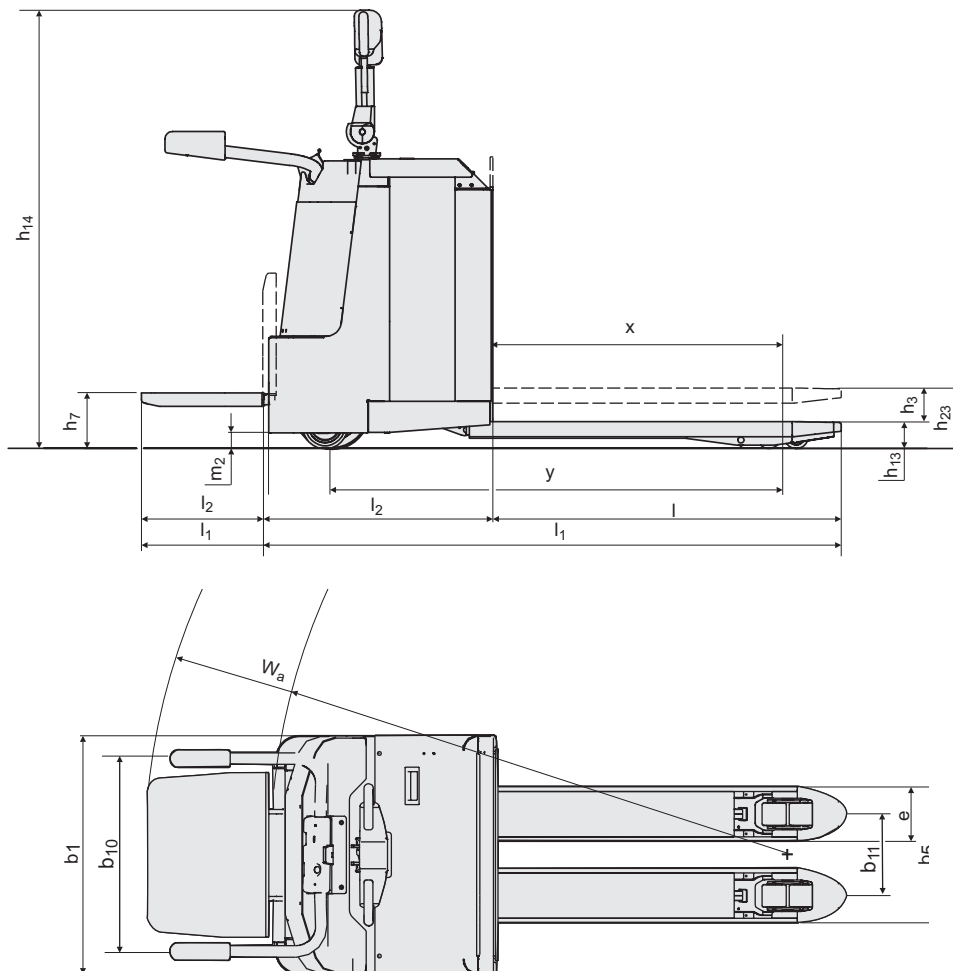

Truck features:

- BT Powerdrive System
- Powertrak traction system
- Fingertip controls
- Information display
- Electronic braking system
- Electronic regenerative brakes
- Driver detection system
- Sideways battery change



TP-Technical Publications, Sweden — 746901-040, version 3, 1203

TOYOTA

MATERIAL HANDLING