



Electric Reach Trucks

Capacity 1000 - 1600 kg
R10B, R12B, R14B, R16B

Series 1120

Safety

With four independent braking systems, fail-to-safe dual circuitry and an impressive range of operator protection features, a safe and efficient working environment is assured.

Performance

Powerful AC traction and lift motors combined with the renowned Linde intelligent controller to deliver seamless, energy efficient performance for best productivity. Torsion-resistant clear view tilt standard or triplex masts ensure smooth, highly efficient storage and retrieval cycles.

Comfort

A world first sees the operator's work station resiliently mounted to the base chassis isolating the operator from shocks and vibrations. An ergonomic, fully adjustable seat and integral control console housing the fingertip joystick hydraulic levers together with a compact steering wheel gives unsurpassed levels of operator comfort. The unique Linde electric steering system enables effortless operation and assured manoeuvring and travelling. In this superb, stress-free working environment, the operator is motivated and can fully focus on the task.

Linde Material Handling

Reliability

Durability and reliability are key elements in delivering cost effective supply chain solutions. Linde reach trucks benefit from the experience of over 50 years working in heavy industrial and commercial applications. All key components are designed and manufactured in-house to achieve these objectives. High residual capacities also result from this knowledge.

Productivity

For low to medium intensity applications requiring cost effective material handling equipment, the highly competitive Linde R10B - R16B reach truck range offers a combination of performance and low operating costs aimed at this important market sector.

Technical Data according to VDI 2198

			R10B	R12B	R14B	R16B	
	Unit	Value	Value	Value	Value	Value	
Characteristics	1.1	Manufacturer	LINDE	LINDE	LINDE	LINDE	
	1.2	Model designation	R10B	R12B	R14B	R16B	
	1.2a	Series	1120-00	1120-00	1120-00	1120-00	
	1.3	Power unit	Battery	Battery	Battery	Battery	
	1.4	Operation	Seat	Seat	Seat	Seat	
	1.5	Load capacity/Load	Q (t)	1.0	1.2	1.4	1.6
	1.6	Load centre	c (mm)	600 / 500	600 / 500	600 / 500	600 / 500
	1.8	Axle centre to fork face	x (mm)	326 ¹⁾	326 ¹⁾	360 ¹⁾	427 ¹⁾
	1.9	Wheelbase	y (mm)	1275	1275	1381	1453
Weights	2.1	Service weight	(kg)	2825 ²⁾	2890 ²⁾	3270 ²⁾	3280 ²⁾
	2.3	Axle load without load, front/rear	(kg)	1750 / 1075	1770 / 1120	1950 / 1320	2015 / 1265
	2.4	Axle load, fork outreached, with load, front/rear	(kg)	725 / 3100	600 / 3490	580 / 4090	645 / 4235
	2.5	Axle load, fork retracted, with load, front/rear	(kg)	1535 / 2290	1512 / 2578	1707 / 2963	1824 / 3056
Wheels/Tyres	3.1	Tyres rubber, SE, pneumatic, polyurethane		Polyurethane	Polyurethane	Polyurethane	Polyurethane
	3.2	Tyre size, front		Ø 360 x 130	Ø 360 x 130	Ø 360 x 130	Ø 360 x 130
	3.3	Tyre size, rear		Ø 285 x 100	Ø 285 x 100	Ø 285 x 100	Ø 285 x 100
	3.5	Wheels, number front/rear (x = driven)		1x / 2	1x / 2	1x / 2	1x / 2
	3.6	Track width, front	b10 (mm)	0	0	0	0
	3.7	Track width, rear	b11 (mm)	1167	1167	1167	1167
Dimensions	4.1	Mast/fork carriage tilt, forward/backward	a/b (°)	2.0 / 2.0	2.0 / 2.0	2.0 / 2.0	2.0 / 2.0
	4.2	Height of mast, lowered	h1 (mm)	2524 ³⁾	3024 ³⁾	2524	2524
	4.3	Free lift	h2 (mm)	150	150	1857	1857
	4.4	Lift	h3 (mm)	3832	4832	5710	5710
	4.5	Height of mast, extended	h4 (mm)	4497 ⁴⁾	5497 ⁴⁾	6382 ⁴⁾	6382 ⁴⁾
	4.7	Height of overhead guard (cabin)	h6 (mm)	2110 ⁵⁾	2110 ⁵⁾	2110 ⁵⁾	2110 ⁵⁾
	4.8	Height of seat/stand on platform	h7 (mm)	910 - 1040	910 - 1040	910 - 1040	910 - 1040
	4.19	Overall length	l1 (mm)	2318 ⁶⁾	2318 ⁶⁾	2390 ⁶⁾	2395 ⁶⁾
	4.20	Length to fork face	l2 (mm)	1168	1168	1240	1245
	4.21	Overall width	b1/b2 (mm)	1270	1270	1270	1270
	4.22	Fork dimensions	s/e/l (mm)	40 x 80 x 1150	40 x 80 x 1150	40 x 80 x 1150	45 x 100 x 1150
	4.23	Fork carriage to ISO 2328, class/type A, B		2A	2A	2A	2A
	4.24	Width of fork carriage	b3 (mm)	880	880	880	880
	4.25	Fork spread, min/max	b5 (mm)	296 / 829	296 / 829	296 / 829	296 / 829
	4.26	Width between reach legs	b4 (mm)	920	920	920	920
	4.28	Reach travel	l4 (mm)	515	515	548	612
	4.31	Ground clearance, below mast	m1 (mm)	90	90	90	90
	4.32	Ground clearance, centre of wheelbase	m2 (mm)	70	70	70	70
	4.33	Aisle width with pallet 1000 x 1200 across forks	Ast (mm)	2644 ⁷⁾⁸⁾	2644 ⁷⁾⁸⁾	2717 ⁷⁾⁸⁾	2740 ⁷⁾⁸⁾
	4.34	Aisle width with pallet 800 x 1200 along forks	Ast (mm)	2703 ⁷⁾⁸⁾	2703 ⁷⁾⁸⁾	2770 ⁷⁾⁸⁾	2780 ⁷⁾⁸⁾
4.35	Turning radius	Wa (mm)	1542 ⁹⁾	1542 ⁹⁾	1640 ⁹⁾	1710 ⁹⁾	
4.37	Length of chassis	l7 (mm)	1639	1639	1737	1817	
Performance	5.1	Travel speed, with/without load	(km/h)	11 / 11 ¹⁰⁾	11 / 11 ¹⁰⁾	11 / 11 ¹⁰⁾	11 / 11 ¹⁰⁾
	5.2	Lifting speed, with/without load	(m/s)	0.51 / 0.57	0.45 / 0.57	0.43 / 0.57	0.4 / 0.57
	5.3	Lowering speed, with/without load	(m/s)	0.55 / 0.55	0.55 / 0.55	0.55 / 0.55	0.55 / 0.55
	5.4	Reach speed, with/without load	(m/s)	0.16	0.16	0.16	0.16
	5.8	Maximum climbing ability, with/without load	(%)	10.0 / 10.0	10.0 / 10.0	10.0 / 10.0	10.0 / 10.0
	5.9	Acceleration time, with/without load	(s)	-	-	-	-
5.10	Service brake		hydr./mech.	hydr./mech.	hydr./mech.	hydr./mech.	
Drive	6.1	Drive motor, 60 minute rating	(kW)	6.5	6.5	6.5	6.5
	6.2	Lift motor, rating at S3 15%	(kW)	14	14	14	14
	6.3	Battery according to DIN 43531/35/36 A,B,C,no		43 531 / C	43 531 / C	43 531 / C	43 531 / C
	6.4	Battery voltage/rated capacity (5h)	(V/Ah)	48 / 420/465 ⁹⁾	48 / 420/465 ⁹⁾	48 / 420/465 ⁹⁾	48 / 420/465 ⁹⁾
	6.5	Battery weight (± 5%)	(kg)	750	750	750	750
	6.6	Power consumption according to VDI cycle	(kWh/h)	upon request	upon request	upon request	upon request
Others	8.2	Operating pressure for attachments	(bar)	-	-	-	-
	8.3	Oil flow for attachments	(l/min)	-	-	-	-
	8.4	Noise level at operator's ear	(dB(A))	64	64	64	64

- 1) -30 mm with int. side shifter
- 2) Alternative batteries may alter l1, Ast and service weight.
- 3) With 150 mm free lift
- 4) with integrated side shifter (with ± 80 mm side stroke)
- 5) With ambient cabin + 95 mm
- 6) Including a 200 mm (min.) operating aisle clearance.

- 7) Some truck specification require a reach-back restriction. Please note information in Linde World mast table.
- 8) Attention, with cabin increased turning radius (Wa) due to required fender.
- 9) forward; backward
- 10) Depending on performance setting

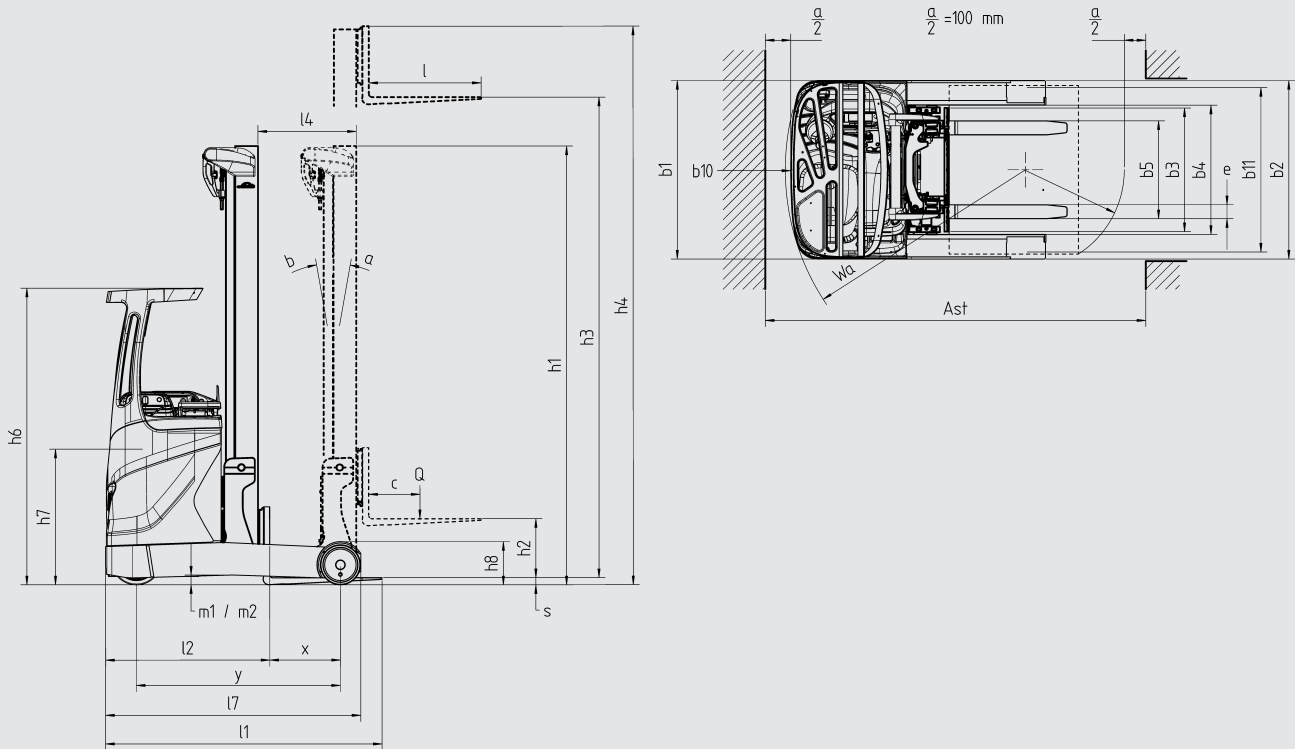

Clear view tilt standard mast (in mm)

R10B, R12B, R14B, R16B

Lift	h3	2932	3232	3532	3832	4032	4232	4532	4832	4932	5132	5332	5532	6032	6532
Free lift	h2	150	150	150	150	150	150	150	150	150	150	150	150	150	150
Height of mast, lowered	h1	2123	2273	2423	2573	2673	2773	2923	3073	3123	3223	3323	3423	3673	3923
Height of mast, extended	h4	3597	3897	4197	4497	4697	4897	5197	5497	5390	5597	5797	6197	6697	7197

Clear view tilt triplex mast (in mm)

R10B, R12B, R14B, R16B

Lift	h3	4460	4610	4910	5210	5410	5710	5860	6210	6510	6660	6960	7260	7560	7710
Free lift	h2	1407	1457	1557	1657	1757	1857	1907	2057	2157	2207	2307	2407	2507	2557
Height of mast, lowered	h1	2074	2124	2224	2324	2424	2524	2574	2724	2824	2874	2974	3074	3174	3224
Height of mast, extended	h4	5132	5282	5582	5882	6082	6382	6532	6882	7182	7332	7632	7932	8232	8382

Alternative lift heights are available on request.

Lift height = h3 + s

Only standard mast: h1 = with 150 mm free lift

Features

Superb working environment

- Outstanding comfort and functionality from the unique, resiliently mounted workstation with a comfort seat that is fully adjustable to the operator's personal preferences
- Integral, adjustable control console incorporating all operating controls
- Linde Load Control: precise, effortless fingertip control of all mast movements
- High Vision armoured glass overhead guard top panel available as an option



Linde twin accelerator pedals

- Seamless and effortless forward/reverse selection provides outstanding traction control and places minimal demands on operator
- His left foot is safely protected within the chassis contours
- The operator is able to maintain high levels of efficiency and productivity



Precision

- Confident, seamless manoeuvring with unique Linde twin accelerator pedal
- High precision load handling with Linde Load Control
- Highly responsive electric steering
- Digital instrument display for instant readout of truck status
- Integral, adjustable operator's control console

Manoeuvrability

- A short wheelbase with compact chassis dimensions and smooth, electric steering ensure easy, efficient manoeuvring and accurate straight line traction performance
- Excellent all-round visibility of the load and surrounding environment



Batteries

- Capacities to suit every application: 420 Ah to 620 Ah
- Rapid and simple battery change - either lift-out or battery on rollers

Stability

- Chassis designed and built for maximum strength and durability
- Heavy-duty design and components enhance the inherent low centre of gravity for optimum stability and high residual capacities
- Linde Curve Assist for safe cornering

Linde clear view mast

- Torsion-resistant, clear view standard and triplex tilt masts
- Twin cylinder configuration for optimum visibility (STD-mast), plus center free lift cylinder on TX-mast
- Hydraulic hoses reeved through the mast to enhance visibility (above chains)



Servicing

- Configurable 1120 B Linde Digital Control system (LDC) incorporates diagnostic technology
- Easy service access
- Maintenance-free AC traction, lift and steer motors
- Up to 1000 operating hours between services

Subject to modification in the interest of progress. Illustrations and technical details could include options and not binding for actual constructions. All dimensions subject to usual tolerances.

ncnielsen

Nørregade 66
7860 Balling

Telefon 99 83 83 83 • fax 97 56 46 24
www.nc-nielsen.dk • linde@nc-nielsen.dk

