

Features



Safety

- Three independent braking systems.
- Asbestos-free brake system components.
- Electric horn.
- Hydraulic overload protection.
- Burst hose check valve.
- Minimal exhaust emissions.
- Excellent all-round visibility.
- Seat belt.
- Overhead guard.

Standard equipment

All items as shown under safety.
Perkins 903.27 diesel engine (H20/H25/H30).
Perkins 903.27 HR diesel engine (H35).
Renault F3R-264 LPG engine (H20/H25).
Perkins G903.27 LPG engine (H30/H35).
Catalytic exhaust converter (LPG).
Lansing hydrostatic transmission.
Automatic engine speed control.
Compact drive axle.
Combined instrumentation and hour meter.
Hydrostatic power steering.
Contoured solid (superelastoc) tyres.
Full suspension PVC seat.
Clearview standard mast – lift height 3 095 mm (H20/H25/H30), 3 100 mm (H35).

Fork carriage – 4 rollers, 1 150 mm wide (H20/H25); 6 rollers, 1 150 mm wide (H30/H35).
Lansing twin accelerator pedal control.
Single lever for lift and tilt functions.
Standard colour scheme – vermilion and charcoal grey.

Optional equipment

Clearview standard masts with lift heights to 4 595 mm (H20/H25/H30), 4 600 mm (H35).
Clearview duplex masts with lift heights to 3 710 mm (H20/H25), 3 760 mm (H30), 3 770 mm (H35).
Clearview triplex masts with lift heights to 6 600 mm (H20/H25), 6 650 mm (H30), 6 665 mm (H35).
Single pedal accelerator with direction lever on steering column.
Individual levers for lift and tilt functions.
Additional hydraulic circuits.
Overhead guard with:
– laminated glass/metal cover
– polycarbonate cover
– cover and front screen and wiper
– cover and front and rear screens, and wipers.
– flexible canopy, front screen and wiper.
Full cab with hinged doors, front and rear screens,

and wipers.
Cab heater.
Rearview mirrors on cab.
Container stuffer version.
Beverage industry version.
Truck lighting.
Working lamp(s).
Flashing amber beacon.
LPG volumetric tank.
Spark arrester.
Engine air pre-filter.
Exhaust particulate filter (diesel).
Twin mounted front wheels.
Pneumatic tyres.
Fabric covered seat.
Integral sideshift.
Load backrest extension.
Fork extensions.
Alternative fork lengths.
Alternative fork carriage widths.
Alternative number of fork carriage rollers.
Reduced travel and/or lowering speed.
Audible warning on reverse travel.
Hydraulic accumulator.
Alternative colour schemes.
Other options available on request.

Lansing Linde Ltd.,
Kingsclere Road, Basingstoke, Hampshire RG21 6XJ.
Tel: (01256) 342000. Fax: (01256) 342923. Web: www.lansinglinde.co.uk
For more information please contact your nearest national network company on **(0845) 608 5000**



Certificate No. FM 342

Linde
Lansing

DM4681/7/00

The manufacturer reserves the right to alter specifications without notice.

Engine powered counterbalance truck 2 000, 2 500, 3 000 and 3 500 kg

Linde
Lansing



Introduction

The superbly styled engine powered models H20, H25, H30 and H35, which comply with EC directives, have been developed to meet the most arduous application requirements.

The unique design features result from a thorough analysis of today's materials handling requirements to achieve maximum productivity. The overall design concept ensures excellent operator comfort and efficiency, contributing significantly to high work throughput with minimum fatigue.

Features

- Operator's compartment developed to provide an unsurpassed working environment for optimum comfort, safety and productivity.
- Unique Lansing hydrostatic control for unequalled performance, reliability and precision.
- Fuel efficient, low noise, low emission engines for reduced operating costs and environmental acceptability.
- Advanced design, full suspension, comfort seat completely adjustable to operator's size and weight.
- A range of clearview masts with excellent visibility for safe, efficient load handling.
- Operator's compartment secured to chassis with hydraulically damped mountings for minimal noise and vibration levels.

Operator's compartment and controls

The spacious operator's compartment has been designed totally with the operator in mind. Every aspect of form and function has been evaluated to maximise the combined efficiency of man and machine for increased productivity.

A low step allows easy access to the operator's compartment which is secured to the chassis by special mountings with hydraulic

suspension for minimal noise and vibration levels to give a superb working environment.

The advanced ergonomic layout of all operating controls ensures optimum comfort, safety and efficiency. The Lansing twin accelerator pedals together with the hydrostatic transmission system make smooth accurate load handling easy, even in confined areas. Low fascia and chassis lines together with a specially profiled overhead guard and clearview mast ensure excellent operator visibility at all times.

The specially designed full suspension seat, complete with seat belt, supports every operational body movement with full adjustment to suit every operator.

The combined instrumentation and hour meter enables cost effective planning of maintenance intervals.

Chassis

The chassis has been designed to achieve maximum strength and rigidity and is completely enclosed to give optimum protection to the engine and other components whilst preventing the ingress of water and dust to these areas.

The functional design also improves operator visibility and minimises noise levels.

Engine and transmission

These models are available with either diesel or LPG powered, liquid cooled engines which, in combination with the hydrostatic transmission and automatic speed control, offer unrivalled performance.

Engine speed is automatically regulated to accurately meet the demands placed on the hydraulic or transmission system. This avoids the high engine rpm associated with conventional trucks and results in reduced fuel consumption, minimal exhaust emissions, lower noise levels and prolonged engine life.

The hydrostatic transmission system provides smooth, infinitely variable control of acceleration, speed and braking. This unique,

virtually maintenance free system, replaces the gear set of a conventional truck, and the hydrostatic braking effect eliminates the need for the normal friction service brakes.

This power pack provides impressive, responsive performance under all operating conditions for increased productivity and reduced maintenance for exceptionally cost effective load handling.

Steering

Hydrostatic power steering requiring exceptionally low steering effort is fitted, which in combination with the specially designed 300 mm diameter steering wheel and the single, double acting steer cylinder, allows a steering lock of 82° for excellent manoeuvrability and maximum operator efficiency with minimum fatigue.

Mast and hydraulics

A range of clearview masts constructed of profiled steel channel for strength and durability is available. The lift cylinders are mounted behind the mast channels for optimum visibility through the mast.

Automatic speed control ensures smooth, precise, energy efficient lift and tilt movements. Sealed for life angled rollers ensure excellent alignment of the moving mast sections for minimal friction during lift and lowering. A single lever operates lift and tilt functions.

Braking

These models are equipped with three independent braking systems:

1. Controlled hydrostatic braking by progressive release of the accelerator pedal.
2. Pressure applied to the brake pedal initiates hydrostatic braking and applies the mechanically operated disc brakes on the front wheels.
3. Failsafe automatic application of the multi-disc brakes in the drive axle when the engine is switched off.

LANSING	Counterbalance truck Designation	Data sheet for materials handling equipment to VDI 3586	351 03 Series no.	VDI 2198
----------------	--	---	-----------------------------	----------

JULY 2000	Manufacturer's data and design characteristics	Model types	Registration note
-----------	---	--------------------	-------------------

Characteristics	1.1 Manufacturer		Lansing		Lansing		Lansing		Lansing		
	1.2 Model designation		H 20 D	H 20 T	H 25 D	H 25 T	H 30 D	H 30 T	H 35 D	H 35 T	
1.3	Power unit: battery, diesel, petrol, LP gas, mains power		Diesel	LPG	Diesel	LPG	Diesel	LPG	Diesel	LPG	
1.4	Operation		Seated		Seated		Seated		Seated		
1.5	Load capacity	Q (t)	2.0		2.5		3.0		3.5		
1.6	Load centre	c (mm)	500		500		500		500		
1.8	Axle centre to fork face	x (mm)	520		520		523		528		
1.9	Wheelbase	y (mm)	1 695		1 715		1 785		1 850		
Weights	2.1	Service weight	kg	3 895	3 675	4 350	4 140	4 895	5 500		
	2.2	Axle load with load, front / rear	kg	5 190/705	5 010/665	6 175/675	6 015/625	7 105/985	8 020/980		
	2.3	Axle load without load, front / rear	kg	1 975/1 920	1 780/1 845	2 090/2 260	1 950/2 190	2 285/2 610	2 510/2 990		
Wheels and tyres	3.1	Tyres, front/rear (SE = CS superelastic, P = pneu)	SE / SE ¹⁾		SE / SE ¹⁾		SE / SE ¹⁾		SE / SE ¹⁾		
	3.2	Tyre size, front	7.00 - 12 ²⁾		7.00 - 12 ²⁾		28 x 9 - 15 ²⁾		28 x 12.5 - 15 ²⁾		
	3.3	Tyre size, rear	6.50 - 10 ²⁾		6.50 - 10 ²⁾		23 x 9 - 10 ²⁾		23 x 9 - 10 ²⁾		
	3.5	Wheels, number front / rear (x = driven)	2 (4) x/2 ³⁾		2 (4) x/2 ³⁾		2 (4) x/2 ³⁾		2 (4) x/2 ³⁾		
	3.6	Track width, front	b ₁₀ (mm)	990 (1 220) ³⁾	990 (1 220) ³⁾	1 053 (1 220) ³⁾	1 042 (1 255) ³⁾				
	3.7	Track width, rear	b ₁₁ (mm)	942	942	932					
	Dimensions	4.1	Mast tilt, forward / backward	α/β (°)	5/9 ⁴⁾	5/9 ⁴⁾	5/9 ⁴⁾	5/9 ⁴⁾			
4.2		Height of mast, lowered	h ₁ (mm)	2 254	2 254	2 248	2 247				
4.3		Free lift	h ₂ (mm)	150	150	150	150				
4.4		Lift	h ₃ (mm)	3 050	3 050	3 050	3 050				
4.5		Height of mast, extended	h ₄ (mm)	3 707	3 707	3 851	3 850				
4.7		Height of overhead guard	h ₆ (mm)	2 250	2 250	2 250	2 250				
4.8		Height of seat	h ₇ (mm)	1 135	1 135	1 135	1 135				
4.12		Towing coupling height	h ₁₀ (mm)	650	650	650	650				
4.19		Overall length	l ₁ (mm)	3 637	3 637	3 736	3 805				
4.20		Length to fork face	l ₂ (mm)	2 637	2 637	2 736	2 805				
4.21		Overall width	b ₁ /b ₂ (mm)	1 164 (1 623) ^{3) 5)}	1 164 (1 623) ^{3) 5)}	1 200 (1 623) ^{3) 5)}	1 336 (1 658) ^{3) 5)}				
4.22		Fork dimensions	s/e/l (mm)	45 x 100 x 1000	45 x 100 x 1000	45 x 100 x 1000	50 x 120 x 1000				
4.23		Fork carriage to DIN 15173, class/form A, B		2A	2A	3A	3A				
4.24		Width of fork carriage	b ₃ (mm)	1 150	1 150	1 150	1 150				
4.31		Ground clearance, mast	m ₁ (mm)	130	130	130	130				
4.32		Ground clearance, centre of wheelbase	m ₂ (mm)	160	160	160	160				
4.33		Aisle width with pallet 1000 x 1200 across forks	A _{st} (mm)	3 990	4 010	4 083	4 158				
4.34		Aisle width with pallet 800 x 1200 along forks	A _{st} (mm)	4 190	4 210	4 283	4 358				
4.35		Turning radius	W _a (mm)	2 270	2 290	2 360	2 430				
4.36		Minimum pivoting point distance	b ₁₃ (mm)	580	580	580	580				
Performance	5.1	Travel speed, with / without load	km/h	21/22	21/21	21/22	21/21	22/23			
	5.2	Lifting speed, with / without load	m/s	0.55/0.58	0.52/0.54	0.54/0.58	0.51/0.53	0.52/0.57	0.46/0.51		
	5.3	Lowering speed, with / without load	m/s	0.52/0.47		0.52/0.47		0.53/0.46	0.49/0.41		
	5.5	Tractive force, with / without load	N	13 500/13 500		15 800/15 800		16 100/16 400	18 500/18 900		
	5.7	Climbing ability, with / without load	%	22/32	23/31	22/31	23/30	19/30			
	5.9	Acceleration time, with / without load	s	5.8/4.8		6.0/5.0		6.2/5.2	6.4/5.4		
	5.10	Service brake		Hydrostatic		Hydrostatic		Hydrostatic			
	Drive	7.1	Engine manufacturer / type (Pe=Perkins, Re=Renault)		Pe. 903.27	Re. F3R-264	Pe. 903.27	Re. F3R-264	Pe. 903.27	Pe. G903.27	
		7.2	Engine performance according to ISO 1585	kW	35	34	35	34	35	39	
		7.3	Rated speed	min ⁻¹	2 100	2 500	2 100	2 500	2 100	2 250	
7.4		Number of cylinders / displacement	cm ³	3/2 700	4/1 998	3/2 700	4/1 998	3/2 700	3/2 700		
7.5		Fuel consumption according to VDI cycle	l/h	2.3	2.3	2.5	2.4	2.7			
Other	8.1	Type of drive control		Hydrost. infinitely variable	Hydrost. infinitely variable	Hydrost. infinitely variable		Hydrost. infinitely variable			
	8.2	Working pressure for attachments	bar	150		175		205			
	8.3	Oil flow for attachments	l/min	34	29	34	29	34			
	8.4	Noise level at operator's ear	dB (A)	76	75.5	76	75.5	76			
	8.5	Towing coupling, design/type, DIN, no		DIN 15170-H		DIN 15170-H		DIN 15170-H			

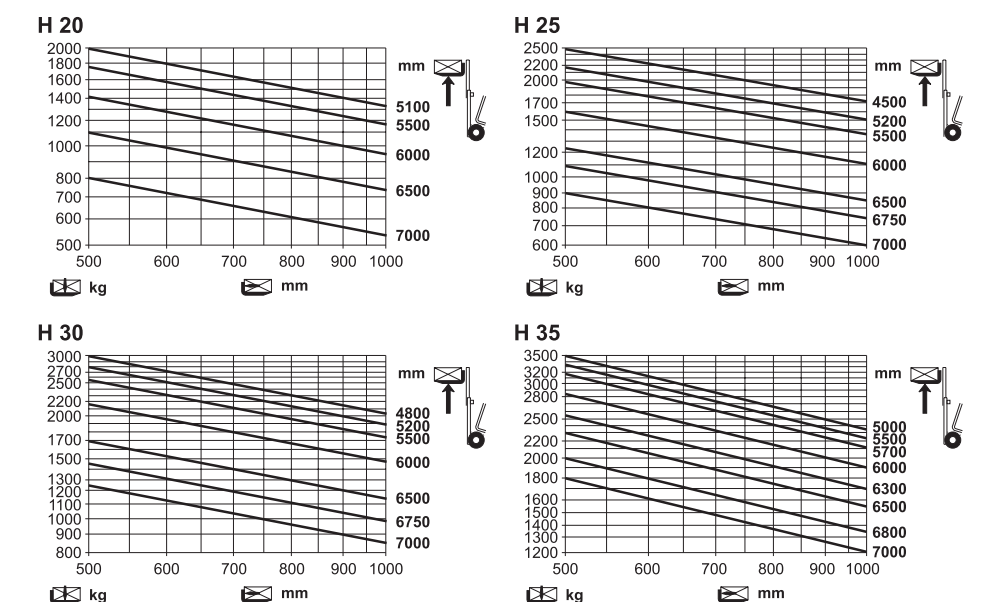
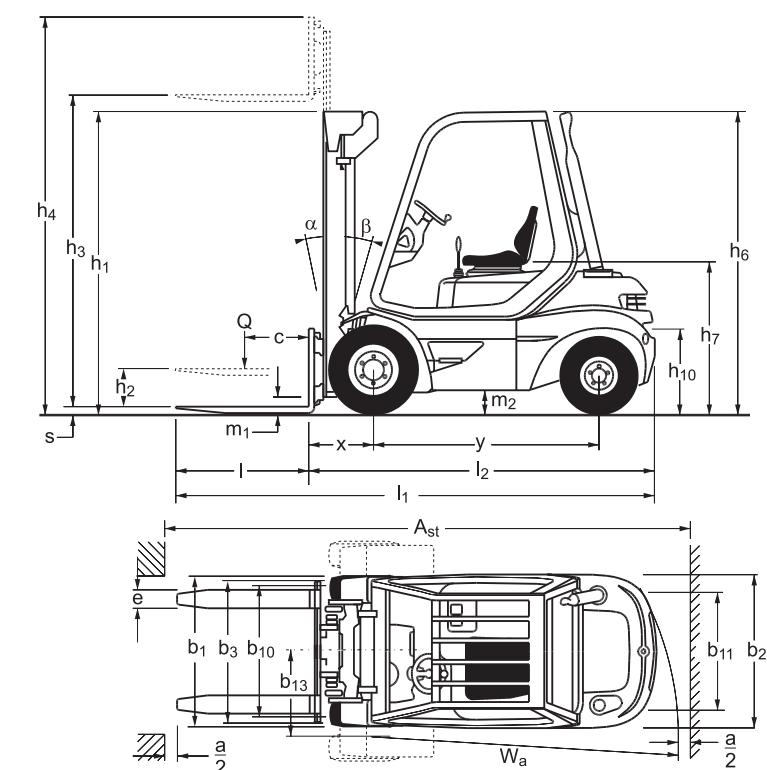

Lifting capacities are for superelastic tyres
Figures for triplex mast on request

		H20/H25 MAST VARIATIONS					Standard clearview			Duplex clearview			Triplex clearview		
H20/H25 MAST VARIATIONS	h ₃	Lift	2 850	3 050	3 450	4 050	4 550	2 865	3 165	3 665	4 265	4 655	5 305	5 905	6 555
	h ₃ +s	Lift height	2 895	3 095	3 495	4 095	4 595	2 910	3 210	3 710	4 310	4 700	5 350	5 950	6 600
	h ₂	Free lift	150	150	150	150	150	1 424	1 574	1 824	1 424	1 574	1 824	2 024	2 274
	h ₁	Height of mast, lowered ⁶⁾	2 154	2 254	2 454	2 754	3 004	2 072	2 222	2 472	2 072	2 222	2 472	2 672	2 922
h ₄	Height of mast, extended	3 507	3 707	4 107	4 707	5 207	3 513	3 813	4 313	4 913	5 303	5 953	6 553	7 203	
H30 MAST VARIATIONS	h ₃	Lift	2 850	3 050	3 450	4 050	4 550	2 915	3 215	3 715	4 315	4 705	5 355	5 955	6 605
	h ₃ +s	Lift height ⁵⁾	2 895	3 095	3 495	4 095	4 595	2 960	3 260	3 760	4 360	4 750	5 400	6 000	6 650
	h ₂	Free lift	150	150	150	150	150	1 274	1 424	1 674	1 274	1 424	1 674	1 874	2 124
	h ₁	Height of mast, lowered ⁶⁾	2 148	2 248	2 448	2 748	2 998	2 075	2 225	2 475	2 075	2 225	2 475	2 675	2 925
h ₄	Height of mast, extended	3 651	3 851	4 251	4 851	5 351	3 716	4 016	4 516	5 116	5 506	6 156	6 756	7 406	
H35 MAST VARIATIONS	h ₃	Lift	2 850	3 050	3 450	4 050	4 550	2 920	3 220	3 720	4 325	4 715	5 365	5 965	6 615
	h ₃ +s	Lift height ⁵⁾	2 900	3 100	3 500	4 100	4 600	2 970	3 270	3 770	4 375	4 765	5 415	6 015	6 665
	h ₂	Free lift	150	150	150	150	150	1 274	1 424	1 674	1 274	1 424	1 674	1 874	2 124
	h ₁	Height of mast, lowered ⁶⁾	2 147	2 247	2 447	2 747	2 997	2 065	2 215	2 465	2 074	2 224	2 474	2 674	2 924
h ₄	Height of mast, extended	3 650	3 850	4 250	4 850	5 350	3 711	4 011	4 511	5 125	5 515	6 165	6 765	7 415	

1) Optional pneumatic tyres
2) Alternative tyre sizes and twin front wheels as optional extra
3) Figures in brackets refer to twin front wheels
4) Optional specifications may alter mast tilt angles. Tilt speed = 1° per second above 5 000 mm lift
5) Alternative tyre equipment may alter overall width b₁
6) With 150 mm free lift on standard mast